

YS Series Y-Strainers

1/2" - 2" PVC, CLEAR PVC AND CPVC
2-1/2" - 4" PVC AND CPVC

KEY FEATURES

- Available in PVC, CPVC and Clear PVC Materials
- Horizontal or Vertical Installation
- FPM O-Ring Seals
- 2:1 Open Area Ratio
- Hex Cap for Easy Access to Screen
- Standard Screen has 1/32" Perforation

OPTIONS

- Stainless Steel Perforated or Mesh Strainer Screens Available in Various Sizes and Alloy Materials

MATERIALS

- PVC Cell Class 12454 per ASTM D1784
- Clear PVC Cell Class 12454 per ASTM D1784
- CPVC Cell Class 23447 per ASTM D1784
- FPM and EPDM O-Ring Seals

TECHNICAL INFORMATION

EXPLODED VIEW

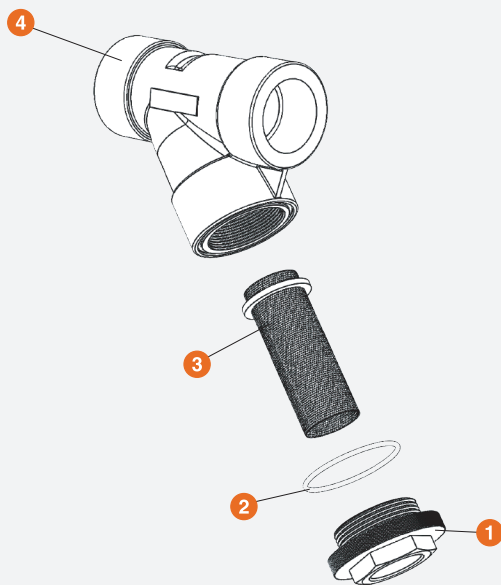

SELECTION CHART

SIZE	MATERIAL	END CONNECTION	SEALS	PRESSURE RATING
1/2" - 1" (DN15 - DN25)	PVC, CPVC or Clear PVC	Socket or Threaded	FPM and EPDM	150 PSI @ 70°F 10 Bar @ 21°C Non-Shock
1-1/4" (DN32)	PVC and Clear PVC			
1-1/2" (DN40)	PVC, CPVC or Clear PVC	Socket, Threaded or Flanged		
2" (DN50)				
2-1/2" (DN65)	PVC			
3-4" (DN80-DN100)	PVC and CPVC			

* PVC and CPVC available with threaded ends to BS21.

YS Series Y-Strainers

1/2" - 2" PVC, CLEAR PVC AND CPVC
2-1/2" - 4" PVC AND CPVC

TECHNICAL INFORMATION, CONTINUED

PARTS LIST

1. Cap
2. O-Ring Seal
3. Screen
4. Body

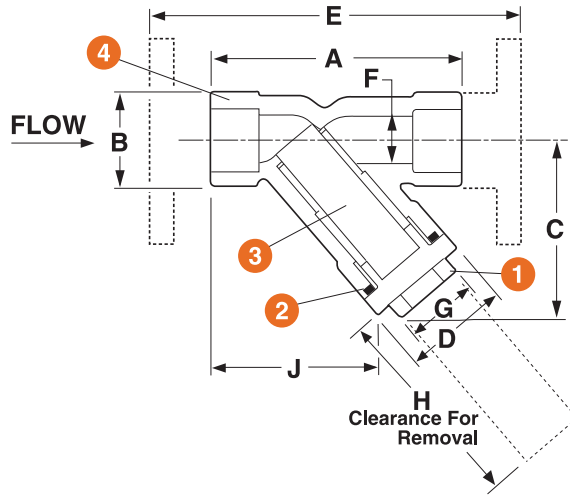

SCREEN OPTIONS

PERFORATION SIZES	MESH SIZES	SCREEN MATERIAL
1/32"	20	SSTL, Hastelloy, Monel and Titanium
1/16"	40	
1/8"	60	
5/32"	80	
3/16"	100	
1/4"	200	
1/32"	N/A	PVC, CPVC
1/16"		
1/8"		
3/16"		

DIMENSIONS

SIZE in / DN	A in / mm	B in / mm	C in / mm	D in / mm	E in / mm	F in / mm	G in / mm	H in / mm	J in / mm	WEIGHT lbs / kg	
										SOC / THD	FLANGED
1/2 / 15	3.38 / 86	1.38 / 35	2.25 / 57	1.50 / 38	N/A	.56 / 14	1.00 / 25	2.13 / 54	2.50 / 64	.25 / .11	N/A
3/4 / 20	4.18 / 106	1.69 / 43	2.88 / 73	2.00 / 51	N/A	.81 / 21	1.25 / 32	2.75 / 70	3.00 / 76	.63 / .29	N/A
1 / 25	5.19 / 132	2.00 / 51	3.63 / 92	2.16 / 55	N/A	1.00 / 25	1.50 / 38	3.30 / 84	3.32 / 84	.88 / .40	N/A
1-1/4 / 32	6.63 / 168	2.63 / 67	4.50 / 114	2.94 / 75	N/A	1.25 / 32	2.00 / 51	4.50 / 114	4.45 / 113	1.75 / .79	N/A
1-1/2 / 40	6.63 / 168	2.63 / 67	4.50 / 114	2.94 / 75	N/A	1.56 / 40	2.00 / 51	4.50 / 114	4.45 / 113	1.63 / .74	N/A
2 / 50	7.63 / 194	3.38 / 86	5.38 / 137	3.75 / 95	11.00 / 279	2.00 / 51	2.38 / 60	5.06 / 129	4.88 / 124	3.00 / 1.36	5.00 / 2.27
2-1/2 / 65	10.31 / 262	4.69 / 119	7.25 / 184	5.25 / 133	N/A	2.90 / 74	3.50 / 89	6.60 / 168	6.54 / 166	7.75 / 3.52	N/A
3 / 80	10.31 / 262	4.69 / 119	7.25 / 184	5.50 / 140	14.37 / 365	2.90 / 74	3.50 / 89	6.60 / 168	6.54 / 166	7.50 / 3.40	12.25 / 5.56
4 / 100	12.81 / 325	5.75 / 146	8.88 / 226	6.18 / 157	17.73 / 450	3.78 / 96	4.25 / 108	8.00 / 203	8.58 / 218	9.50 / 4.30	17.50 / 7.94

Dimensions are subject to change without notice – consult factory for installation information

Cv VALUES*

SIZE in / DN	Cv VALUES	SIZE in / DN	Cv VALUES	PRESSURE LOSS CALCULATION FORMULA
1/2 / 15	4.0	2 / 50	28	$\Delta P = \left[\frac{Q}{C_v} \right]^2$ $\Delta P = \text{Pressure Drop}$ $Q = \text{Flow in GPM}$ $C_v = \text{Flow Coefficient}$
3/4 / 20	6.8	2-1/2 / 65	40	
1 / 25	9.0	3 / 80	65	
1-1/4 / 32	12	4 / 100	100	
1-1/2 / 40	28			

* With 1 / 32" plastic screen

OPERATING TEMPERATURE/PRESSURE

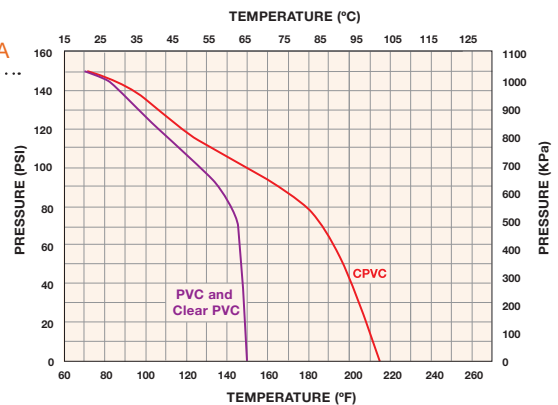

Hayward is a registered trademark of Hayward Industries, Inc. © 2019 Hayward Industries, Inc.

USA: 1.888.429.4635 • Fax: 1.888.778.8410 • One Hayward Industrial Drive • Clemmons, NC 27012 • Email: hfcsales@hayward.com
Canada: 1.888.238.7665 • Fax: 1.905.829.3636 • 2880 Plymouth Drive • Oakville, ON L6H 5R4 • Email: hfcanada@hayward.com
Visit us at: haywardflowcontrol.com